

Builders' Bulletin: Building a Deck

For a Single Family Dwelling

This Bulletin is designed to assist anyone considering building a deck. In addition to [submitting a Permit Application](#) and a site plan, please be sure to consult the relevant Village of Pemberton Bylaws or contact Staff if you have questions: developmentsservices@pemberton.ca

The drawings below indicate the requirements specified by the *BC Building Code*.

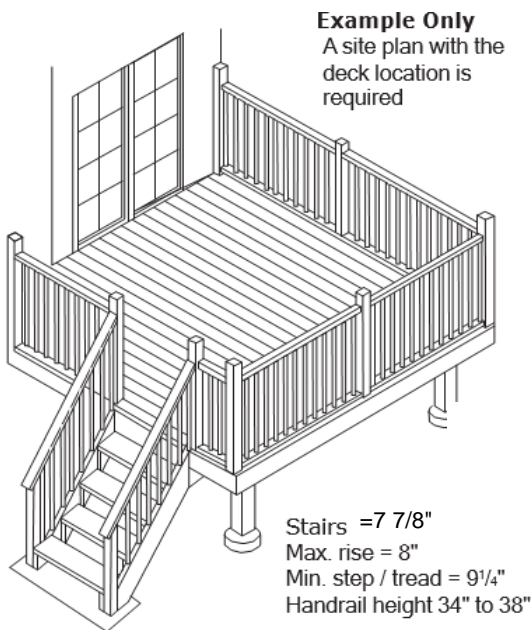

Guardrail Design

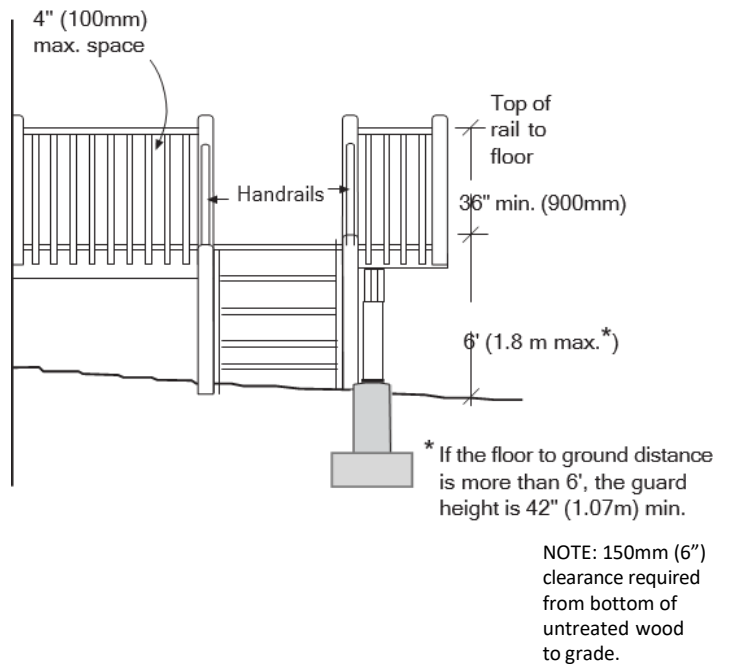

Framing Details

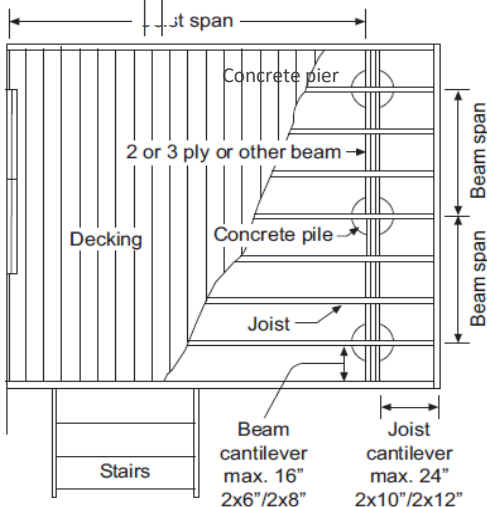

NOTE: Maximum cantilevers apply when joists carry uniform distributed roof loads. Other point loads to transfer directly to the foundation.

Foundation Options

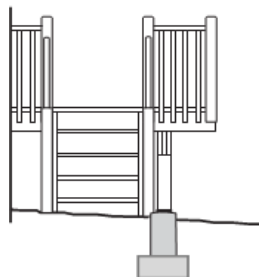

Permanent foundations

Required when decks are attached to the house and if a roof structure or other enclosure will be constructed. Permanent foundations such as 24" x 24" footings 2' below grade are required. **Additional detail drawings must be submitted** for review.

Checklist: Deck or a Single Family Dwelling

Application Requirements

A **standard building permit application** can be located on the Village of Pemberton website and is required for a deck. The following items must be completed and submitted:

- Forms A/B/C (Item 1)
- Scope of work (Item 2)
- Current Certificate of Title (within last 30 days), and copies of registered documents (easements, covenants & right-of-ways) may be required (Item 6)
- Engineer's Design and Schedule B and proof of insurance, if applicable (Item 8)
- Strata Authorization is required if applicable (Item 11)
- Two paper sets and one PDF set of scaled plans which shall include:
 - All dimensions, lot size and accurate shape showing the size of the proposed deck.
 - The exact location of the proposed deck in reference to other structures, property lines, all registered easements, right-of-ways, existing retaining walls and proposed retaining walls.
 - Working drawings shall show all building elevations, foundation/footing plans, and a cross-section showing all construction assemblies.
 - The material and design of the deck and the location and specifications of guard railings.
 - Plans must be drawn to scale. Preferred scale Metric 1:50 or Imperial ¼" = 1.0 ft.
 - All construction shall conform to the *BC Building Code*. **Refer to drawings above for code standards for decks.**

Please consult the [Village of Pemberton Zoning Bylaw](#) to ensure your deck is compliant with zoning requirements. If you are unsure of your zone or need assistance contact the Village at 604-894-6135 or by email developmentsservices@pemberton.ca